

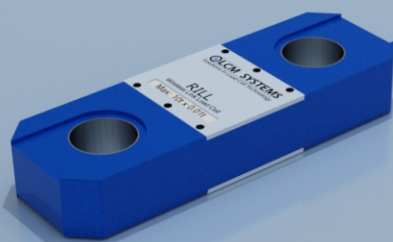

TYPE: RILL



RILL Wireless Load Link

Features

- Ranges from 1 to 300 tonnes
- Lightweight aluminium construction
- High accuracy
- Environmentally sealed to IP67
- License Free 2.4GHz radio
- Internal antennae
- 1200 hours battery life using standard AA batteries
- Can be supplied with various bespoke telemetry and/or software packages

Typical Applications

- Underhook crane weighing
- Cable tension monitoring
- Crane/hoist proof loading
- Water weights calibration
- Warehouse despatch weighing

AVAILABLE TO BUY ONLINE

Visit our website www.lcmsystems.com
(In-stock items usually ship within 48 hours)

Description

The LCM RILL series have been designed for lifting and weighing in rugged or harsh environments. Being manufactured from high tensile aluminium to minimise weight also makes them ideal for mobile use (steel brushed holes provide added wear protection from shackles etc).

The RILL load link range is simple to install and are matched to standard shackle sizes. They are supplied complete with a battery powered handheld indicator, which will display the load in tonnes or pounds (other measurement units are available on request). The handheld indicator is very easy to operate, with just three buttons. One turns the unit On/Off, one toggles between Gross/Net, and the third allows you to switch units from tonnes to pounds and vice versa.

The RILL is supplied as standard without any additional wireless devices to enable greater flexibility with the configuration and ordering of the product. The RILL can be used with any of the T24 range of wireless instrumentation, whether this be for a simple display system using the T24-HS-LS, or more complex systems using multiple load cells and multiple wireless devices.

For more sophisticated systems, including datalogging or monitoring/reporting requirements, we are able to offer a robust tablet PC with installed software for use with single or multiple load cell installations. Our sales team will be happy to discuss the best wireless system configuration to suit your requirements.

Specification

Rated load (tonnes)	1, 2.5, 6.5, 12, 25, 35, 55, 75, 100, 150, 200, 250, 300
Proof load	200% of rated load
Safety factor	1200% of rated load (1 te) 700% of rated load (2.5, 6.5, 12 te) 500% of rated load (25, 35, 55, 75, 100, 200, 300 te) 400% of rated load (150, 250 te)
Display (T24-HS)	7 digit LCD, 9mm high digits
Accuracy	<±0.3% of rated load
Power supply	4 x AA alkaline batteries for load link
Battery life	1200 hours continuous use for load link
Transmission range	700 metres (clear line of sight)
Radio frequency	2.4GHz
Update rate	Standard is 3 per second
Operating temperature range	-10 to +50°C
Compensated temperature range	-10 to +50°C
Zero temperature coefficient	<±0.02% of rated load/°C
Span temperature coefficient	<±0.02% of rated load/°C
Environmental protection level	IP67

Available Options

- Wireless overload alarm module
- Wireless base station with analogue output
- Wireless signal booster
- Multiple wireless load cell controller software
- Wireless slave display
- Crosby shackle supply



SCIGATE AUTOMATION (S) PTE LTD

No 1 Bukit Batok Street 22 #01-01 Singapore 659592
Tel: (65) 6561 0488 Fax: (65) 6561 0588
Email: sales@scigate.com.sg Web: <https://scigate.com.sg/>

Business Hours: Monday - Friday 8:30AM - 6:15PM

RILL Wireless Load Link

Dimensions

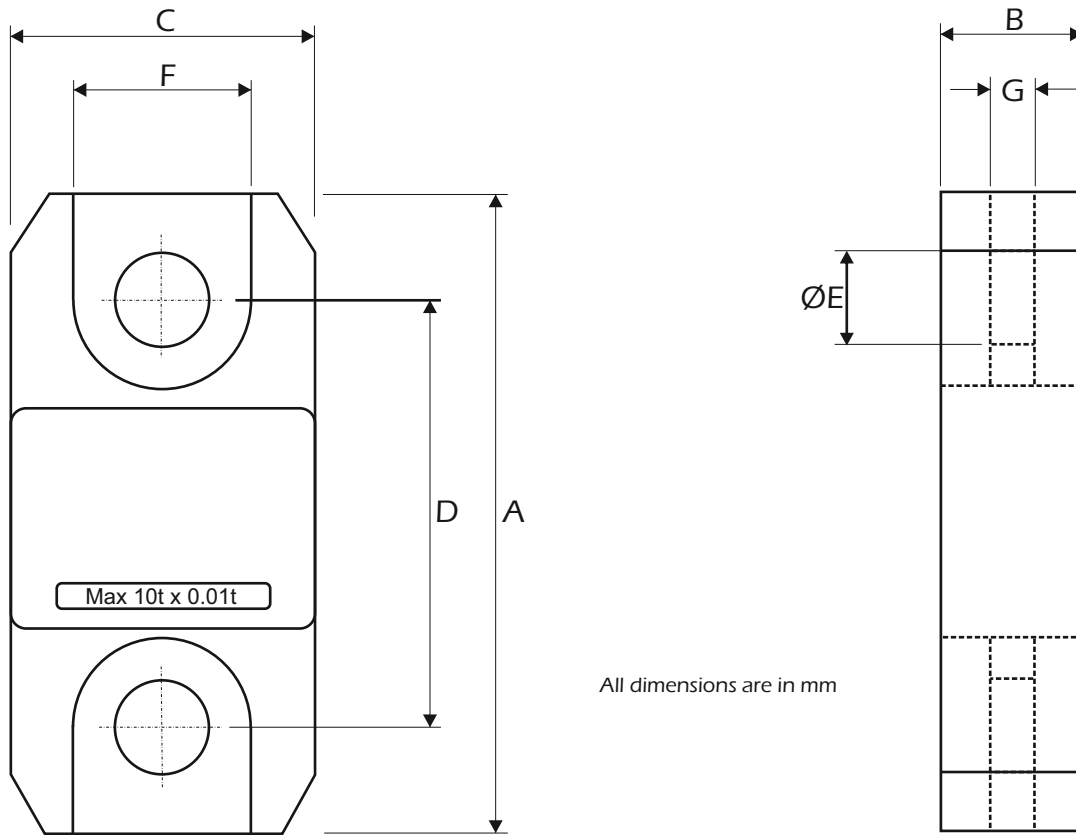

Rating (tonnes)	A	B	C	D	ØE	F	G	Resolution (tonnes)	Resolution (lbs)	Weight (kg)
1	204	43	104	146	24.5	48	19	0.0005	1	1.5
2.5	204	43	104	146	24.5	48	19	0.001	2	1.5
6.5	249	43	113	165	38	66	32	0.001	2	2.4
12	305	47	113	193	47.5	N/A	N/A	0.002	5	3.7
25	340	60	115	215	55	N/A	N/A	0.005	10	5
35	393	75	126	225	60	N/A	N/A	0.005	10	8.6
55	424	75	180	230	76	N/A	N/A	0.01	20	13
75	470	75	202	260	76	N/A	N/A	0.01	20	16
100	608	99	255	320	109	N/A	N/A	0.05	100	34
150	670	99	303	360	109	N/A	N/A	0.05	100	46
200	700	144	350	350	145	N/A	N/A	0.1	200	82
250	700	144	350	350	145	N/A	N/A	0.1	200	82
300	806	150	426	350	160	N/A	N/A	0.1	200	118

A summary of available wireless devices that can be used to enhance the AWLL in your application can be viewed on the next page of this datasheet.

For further assistance on system configuration, please call us or email your requirements to sales@lcmssystems.com.

RILL Wireless Load Link

Wireless Receivers/Display Options



T24-HS-LS
Simple wireless display for connecting to 1 load cell



T24-HA
Wireless display for connection to up to 12 load cells



T24-HR
Wireless display for connecting to multiple load cells



X24-HD
ATEX Wireless display for connection to up to 24 load cells



Wireless Base Station Options



T24-BSu
Wireless USB connected base station



T24-Bsd
Wireless compact USB connected dongle base station



T24-BSue
Wireless USB extended range base station



T24-BSi
Wireless USB, RS485, RS232 connected base station

Wireless Output Module Options



T24-RM1
Wireless relay, switch output module



T24-SO
Wireless serial ASCII output module



T24-AO1
Wireless analogue output module



T24-PR1
Wireless surface mounting tally roll printer



T24-AR
Wireless range extender repeater module

Wireless Software Options



LCM Systems are able to offer various software solutions for our wireless range of load cells. We encourage you to speak to our sales team to discuss any standalone software requirements you may have.

The solutions we regularly offer include centre of gravity weighing and reporting, multiple load cell display & reporting and PC based datalogging. Other solutions can also be offered.

For more detailed information regarding wireless instrumentation visit www.lcmsystems.com/T24

www.lcmsystems.com

LCM Systems Ltd

Unit 15, Newport Business Park, Barry Way
Newport, Isle of Wight PO30 5GY UK
Tel: +44 (0)1983 249264
sales@lcm systems.com
www.lcm systems.com

LCM Systems (România)

Strada Ștefan Cel Mare 26a,
Tunari, cod.077180, Ilfov, România
Tel: +40 (0)77 4641899
ro@lcm systems.com
www.lcm systems.ro

Due to continual product development, LCM Systems Ltd reserves the right to alter product specifications without prior notice.

Issue No. 6

Issue date: 04/11/2021
APPROVED
(unapproved if printed)